

Overview

The LBC-4000 Up/Down Converter System is an L-Band IF to 70 MHz IF (140 MHz optional) indoor converter. It is packaged in a 1RU 19-inch chassis with two front panel accessible up converter or down converter modules. It contains two diode “OR-ed” internal power supplies for increased reliability and microprocessor-based Monitor & Control (M&C) functions.

The LBC-4000 up converter module translates a 70 MHz IF input signal (140 MHz optional) up to a user-selected frequency at L-Band (950 to 2000 MHz). The L-Band output can drive the input of our MBT-4000 block up converter or other RF equipment with an L-Band input.

The LBC-4000 down converter module translates an L-Band (950 to 2000 MHz) IF input signal down to a user selected frequency in the 70 MHz (140 MHz optional) IF band. The LBC-4000 can be locked to an internal reference or an external 5 or 10 MHz reference signal. The LBC-4000 is an excellent choice for interfacing legacy 70 or 140 MHz equipment to quad-band or tri-band block converters.

Features

- Meets or exceeds MIL-STD-188-164A
- Low phase noise
- 1 kHz step size
- Field selectable spectral inversion
- 50 dB gain adjustment
- 70 \pm 18 MHz IF (140 \pm 36 MHz optional)
- Flexible configuration
- Auto band sensing capability
- Redundant option available

Installation

The LBC-4000 is rack mounted in a standard 19-inch equipment rack. External equipment, such as a modem, is connected to each internal converter module by a low-cost coaxial cable. A coaxial cable is also used to connect the output of each module to RF equipment either in the same location or at the antenna location.

Specifications

LBC-4000 L-Band Down Converter IDU

| | |
|------------------------|---|
| Input Frequency Range | 950 to 2000 MHz, 1 kHz steps |
| Output Frequency | 70 ± 18 MHz (140 ± 36 MHz optional) |
| Input/Output Impedance | 50 Ω |
| Input Return Loss | 15 dB minimum |
| Output Return Loss | 20 dB minimum |
| Input Connector | Type N, Female |
| Output Connector | BNC, Female |
| Gain | 35 dB nominal at min. attenuation |
| Ripple | ± .5 dB over any ± 18 MHz for 70 MHz IF units ± .5 dB over any ± 36 MHz for 140 MHz IF units |
| Slope | .05 dB/MHz |
| User Attenuation Range | 0 to 40 dB, in 0.10 dB steps |
| Output Power, P1dB | +13 dBm minimum |
| Third Order Intercept | +23 dBm minimum |
| Carrier Spurious | -60 dBc |
| Non-Carrier Spurious | -60 dBm |
| Stability Over Time | ± 1 x 10 ⁻⁹ /Day |
| Stability Over Temp | ± 1 x 10 ⁻⁸ 32° to 122°F (0° to 50°C) |

LBC-4000 L-Band Up Converter IDU

| | |
|------------------------|---|
| Input Frequency | 70 ± 18 MHz (140 ± 36 MHz optional) |
| Output Frequency | 950 to 2000 MHz, 1 kHz steps |
| Input/Output Impedance | 50 Ω |
| Input Return Loss | 18 dB minimum |
| Output Return Loss | 15 dB minimum |
| Input Connector | BNC, Female |
| Output Connector | N Female |
| Gain | 25 ± 1 dB nominal at minimum attenuation |
| Ripple | ± .5 dB over any ± 18 MHz for 70 MHz IF units ± .5 dB over any ± 36 MHz for 140 MHz IF units |
| Slope | .05 dB/MHz |
| User Attenuation Range | 0 to 50 dB, in 0.10 dB steps |
| Input Power Level | To +10 dBm, maximum |
| Output Power, P1dB | +10 dBm minimum |
| Third Order Intercept | +20 dBm minimum |

| | |
|----------------------|---|
| Carrier Spurious | -60 dBc |
| Non-Carrier Spurious | -75 dBm |
| Transmit Phase Noise | Exceeds MIL-STD-188-164A |
| Stability Over Time | ± 1 x 10 ⁻⁹ /Day |
| Stability Over Temp | ± 1 x 10 ⁻⁸ 32 to 122°F (0° to 50°C) |

Phase Noise

| Frequency Offset | Up Converter (Guaranteed / Typical) | Down Converter (Guaranteed / Typical) |
|------------------|-------------------------------------|---------------------------------------|
| 100 Hz | -76/-79 dBc/Hz | -75/-78 dBc/Hz |
| 1000 Hz | -79/-82 dBc/Hz | -76/-79 dBc/Hz |
| 10000 Hz | -86/-89 dBc/Hz | -87/-90 dBc/Hz |
| 100000 Hz | -107/-110 dBc/Hz | -110/-113 dBc/Hz |
| 1 MHz | -122/-125 dBc/Hz | -126/-129 dBc/Hz |

Physical & Environmental

| | |
|--|--|
| Operating Temperature | -0° to +50°C (32° to 122°F) |
| Operating Altitude | 10,000 ft above sea level |
| Operating Humidity | 5 to 95 non-condensing |
| Non-Operating Temperature | 58° to 160°F (-50° to +71°C) |
| Dissipation | 60 W typical |
| Prime Power | 90 to 260 VAC, 47 to 63 Hz |
| Dimensions (1RU) (height x width x depth) | 1.75" x 19" x 22" (4.45 x 48.30 x 55.90 cm) |
| Weight | 25 lbs (11.34 kg) maximum |

External Reference

| | |
|-----------------|--------------------------|
| Input Frequency | 5 or 10 MHz, Auto detect |
| Input Level | ± 5 dBm |
| Input Impedance | 50 Ω |

Monitor & Control

| | |
|------------------------|---|
| Ethernet M&C/Connector | Ethernet, Telnet, SNMP/RJ-45 |
| Serial M&C/Connector | TIA/EIA-232, TIA/EIA-485, 4-wire, 9-pin D, Female |
| Alarm Contacts | 3 Form C summary |
| Alarm Connector | 9-pin D, Female |

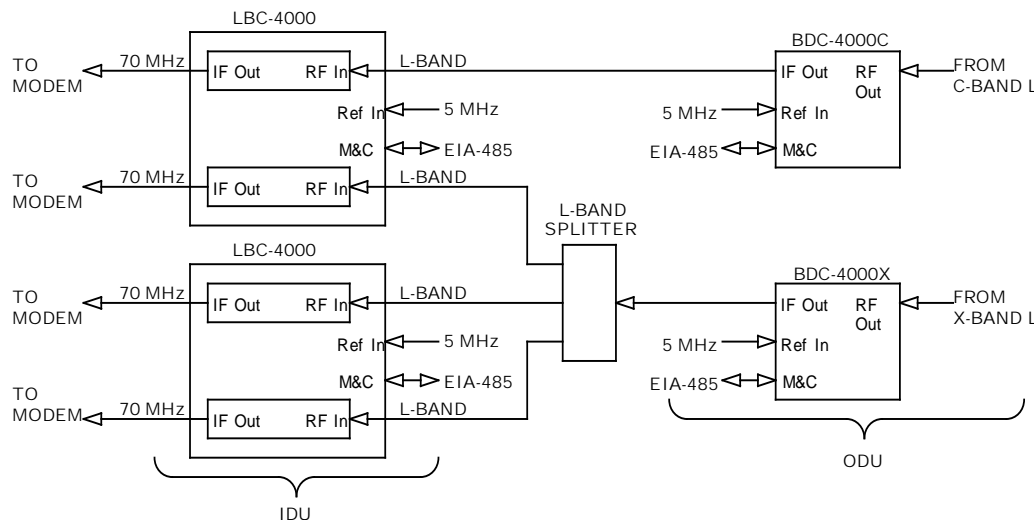

Typical Application



2114 West 7th Street, Tempe, Arizona 85281 USA
Voice: +1.480.333.2200 • Fax: +1.480.333.2540 • Email: sales@comtechefdata.com

See all of Comtech EF Data's Patents and Patents Pending at <http://patents.comtechefdata.com>

Comtech EF Data reserves the right to change specifications of products described in this document at any time without notice and without obligation to notify any person of such changes. Information in this document may differ from that published in other Comtech EF Data documents. Refer to the website or contact Customer Service for the latest released product information

© 2014 Comtech EF Data

ds-lbc4000.docx

9/11/2014



Planet Communications Asia PLC.

157 Soi Ramindra 34, Ramindra Rd., Tarang, Bangkok, Bangkok 10230
Tel: +66 2 792 2400 | Fax: +66 2 792 2499, +66 2 943 5771 | E-mail: sales@planetcomm.com



PlanetComm: